

robodacta.mx
robótica didáctica

Manual de ensamble

Kit RanaBot

Código KIT1419

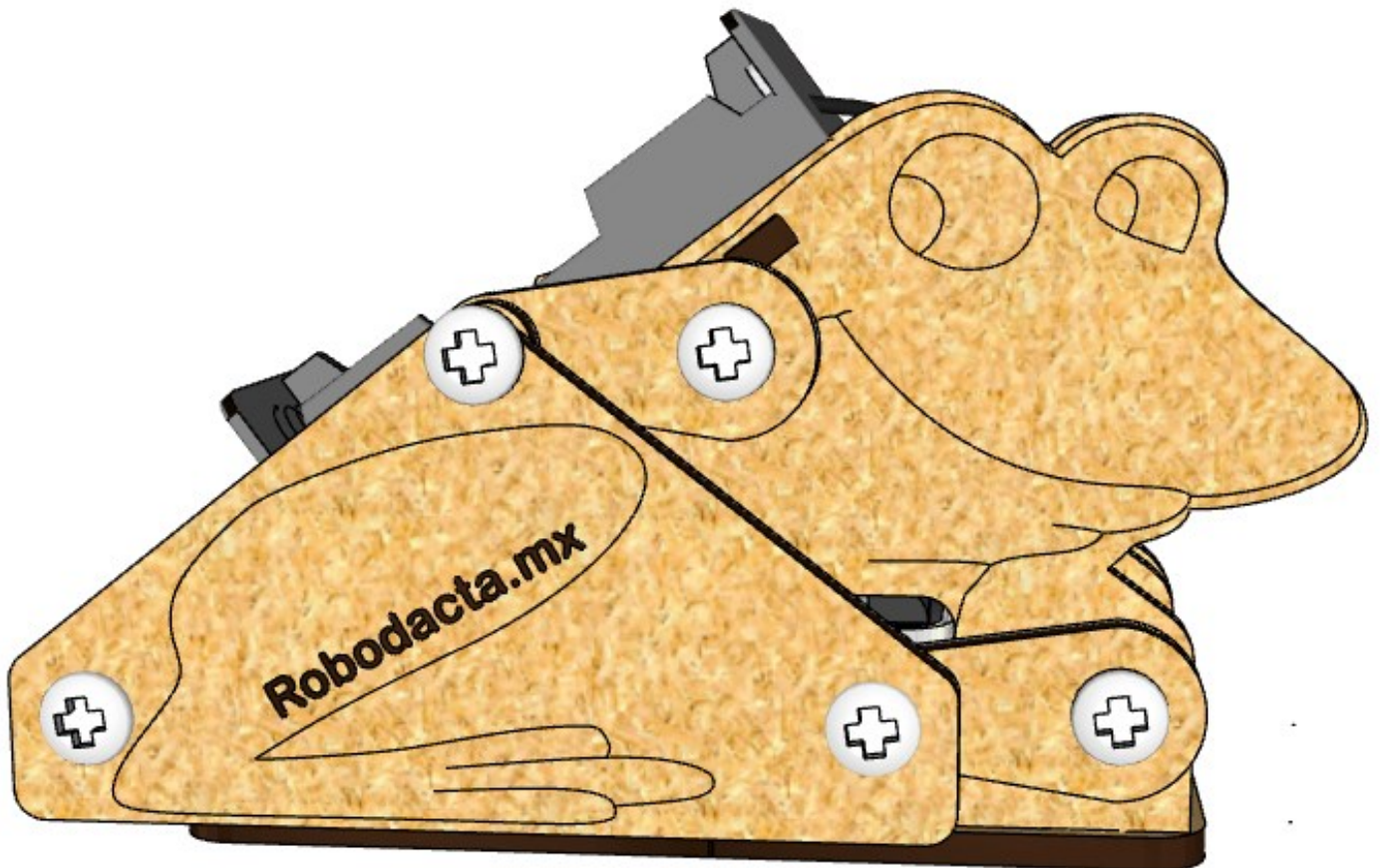

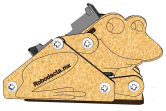

2

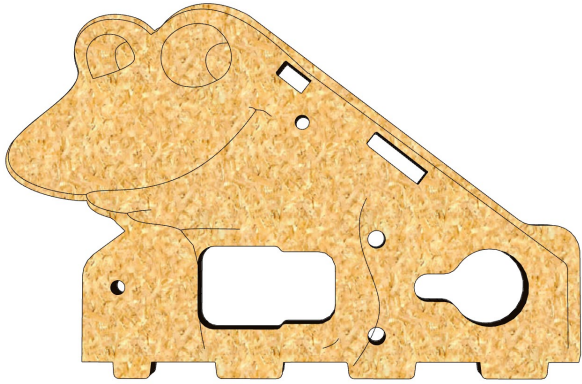

x1

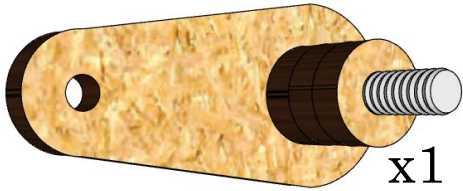

x1

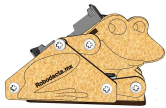
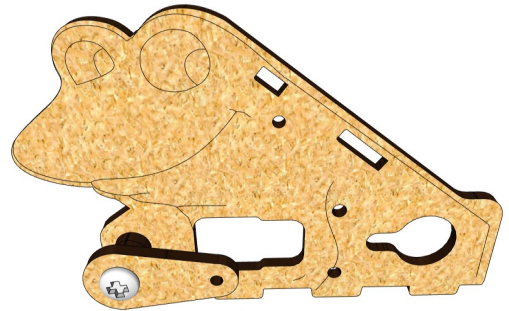
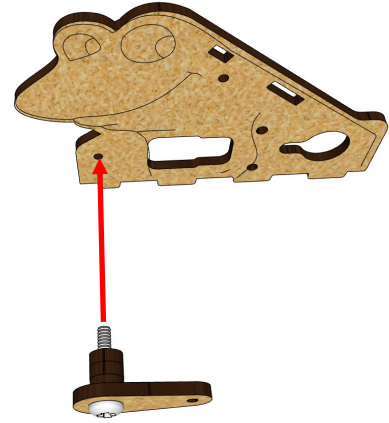

3

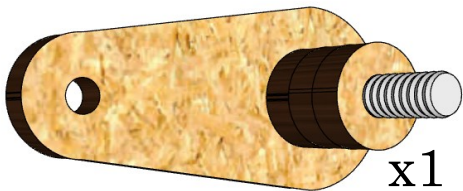

x1

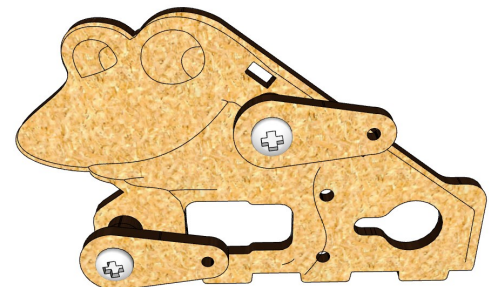
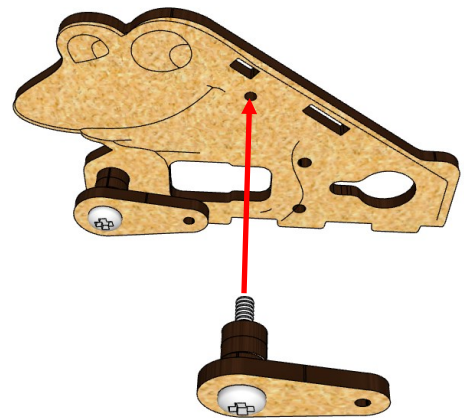

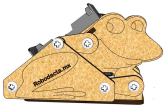

4

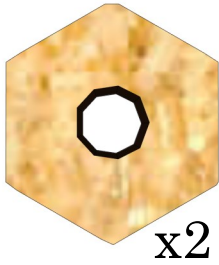
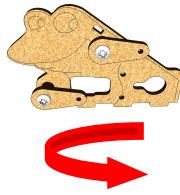

Nota: al colocar las tuercas de MDF ajusta asta el tope y regresa 1/2 de vuelta.

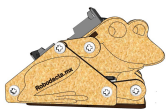

5

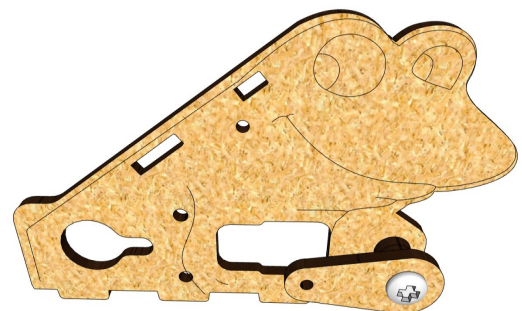
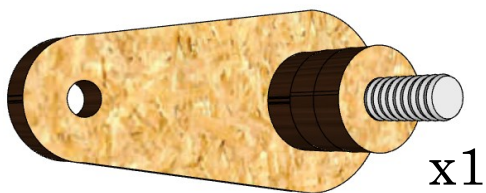
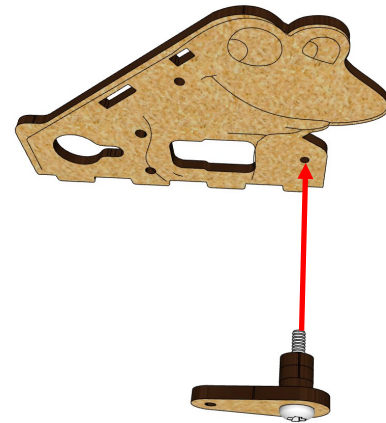
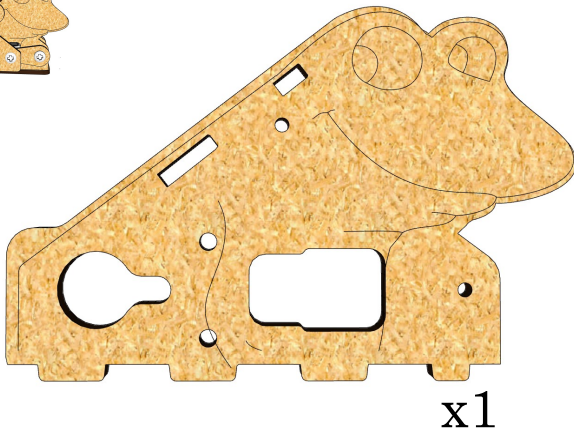

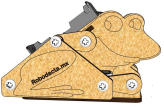

6

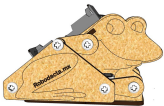
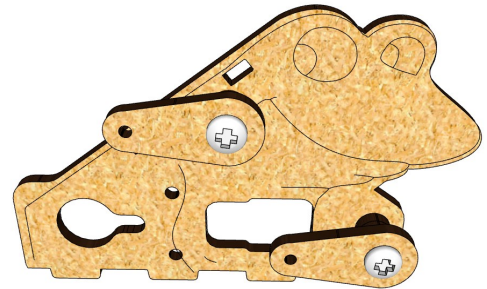
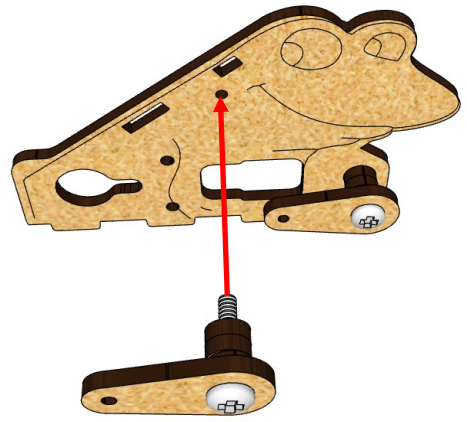
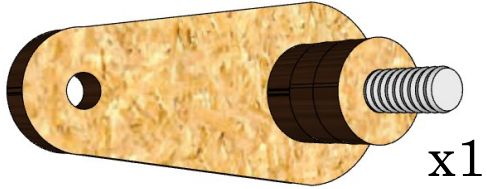

7

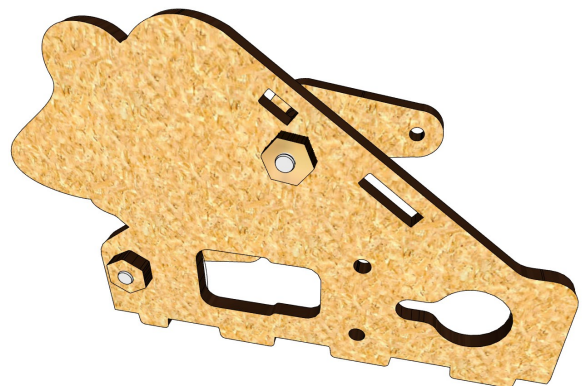
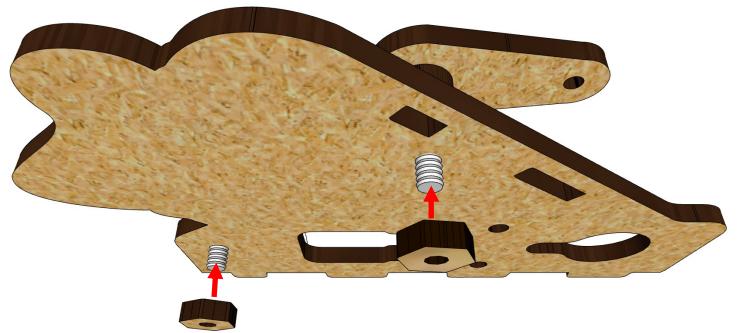
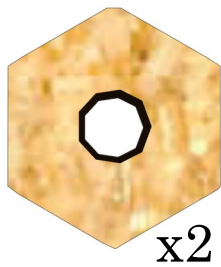

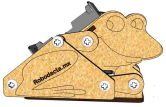

8

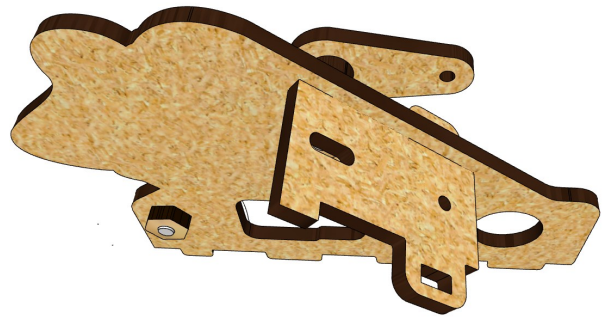
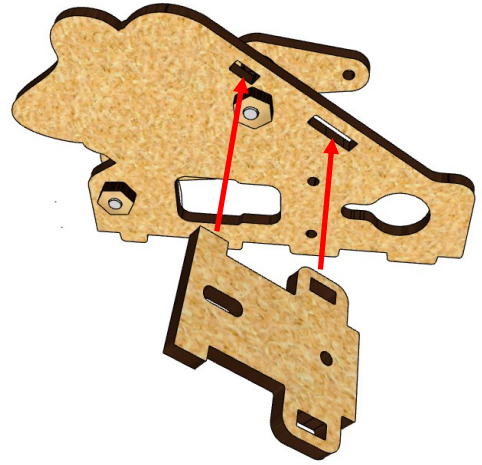
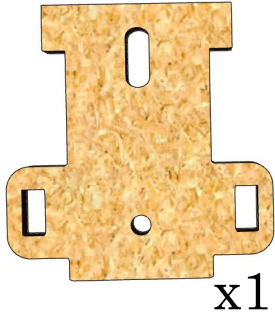

9

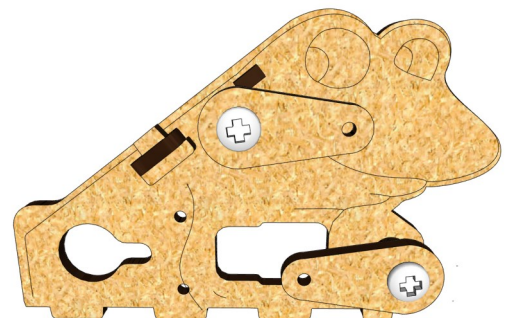
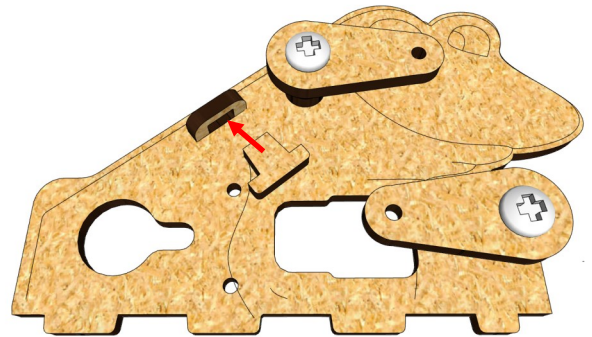
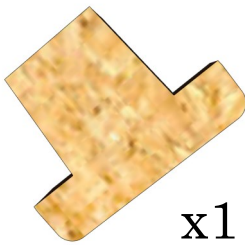

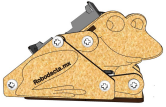

10

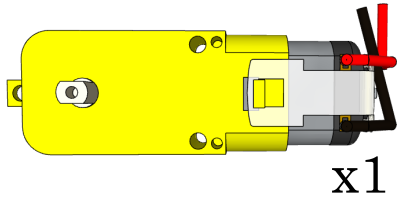

x1

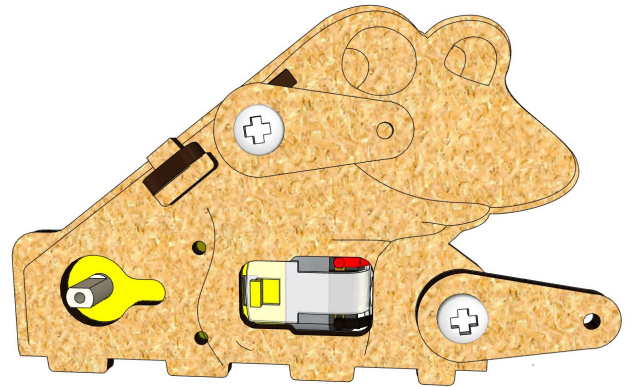
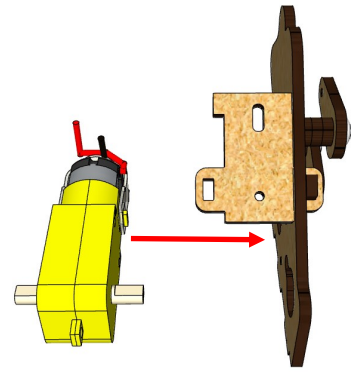

*Nota: los cables de el motor deben ver hacia esta pieza de MDF.
No retires ninguno de los cinturones de seguridad.*



11

M3 x 30

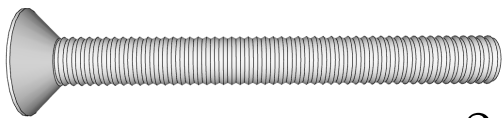

x2

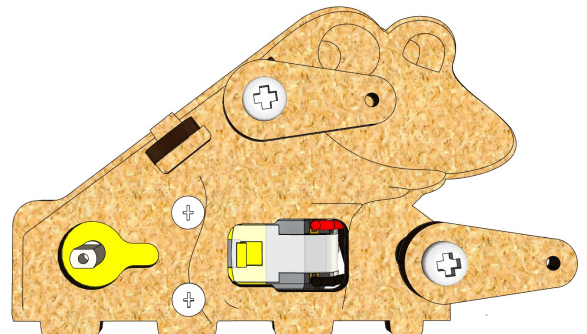
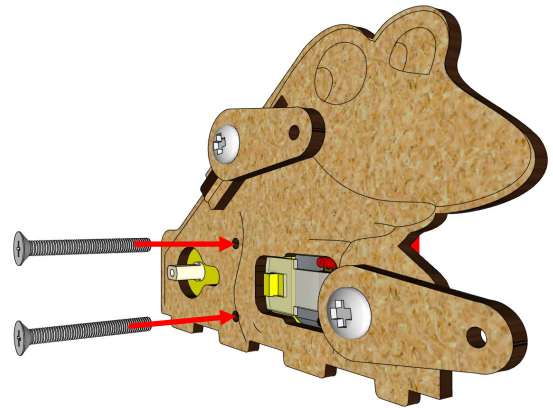

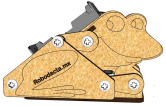

12

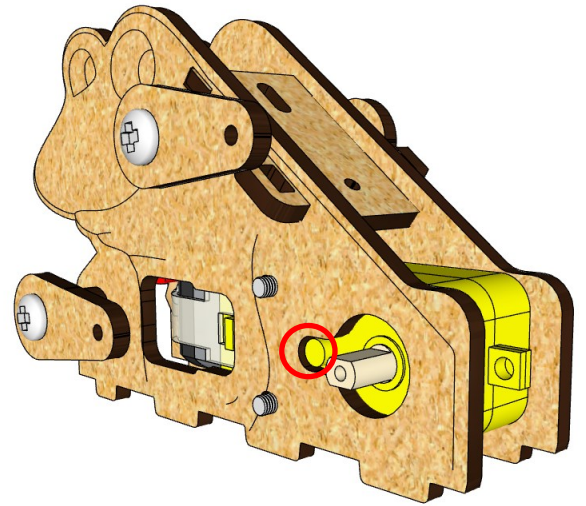
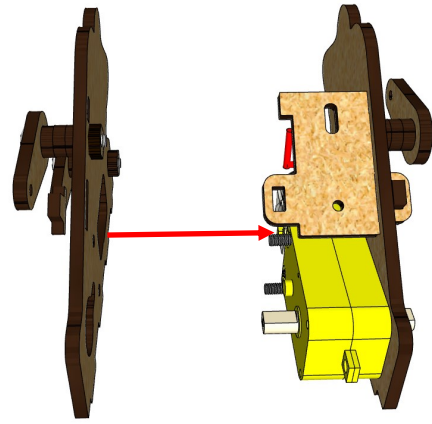
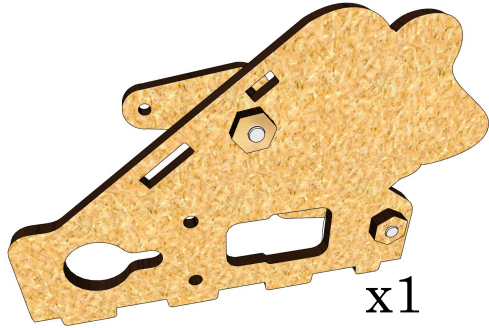

Nota: verifica que el círculo sobresaliente del motor (se encuentra remarcado) este en la posición mostrada.



13

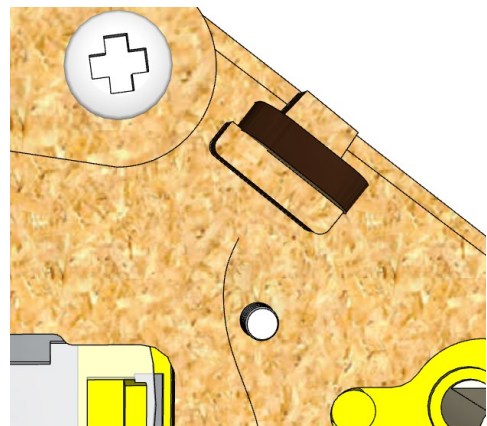
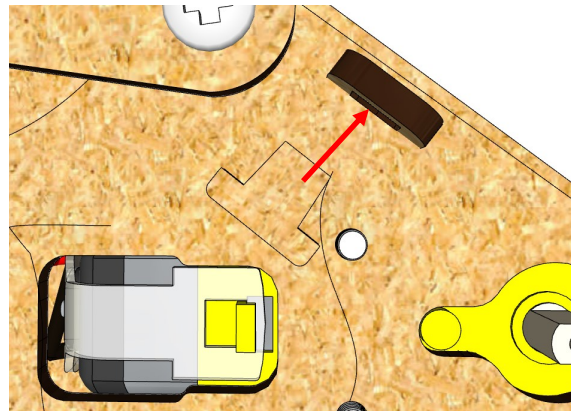
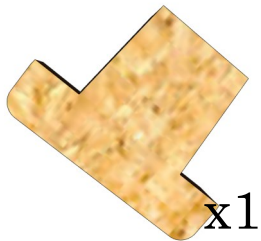

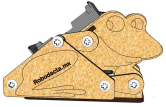

14

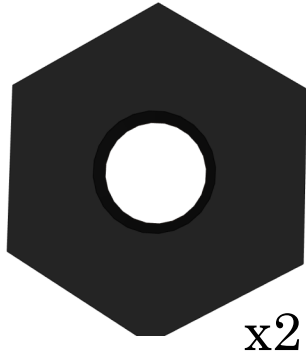

x2

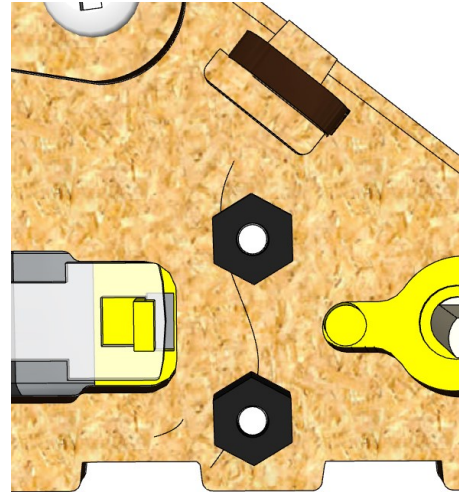
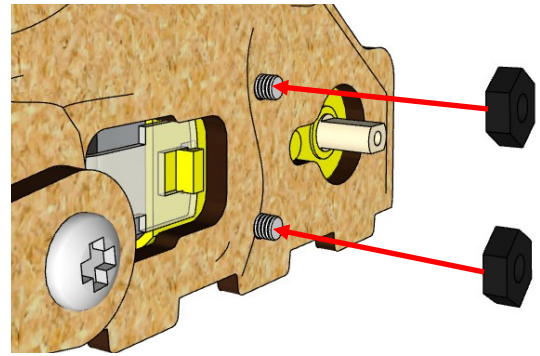

15

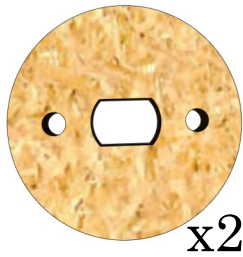

x2

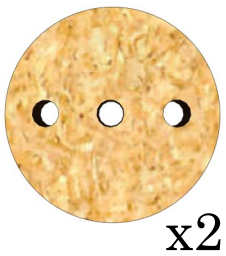

x2

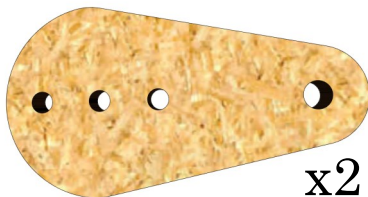

x2

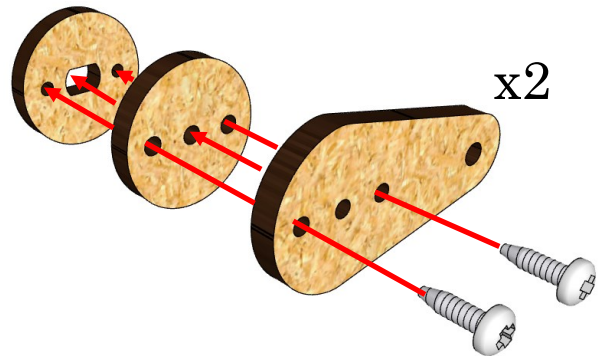

x2

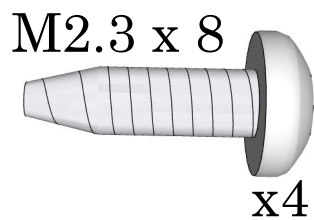

x4

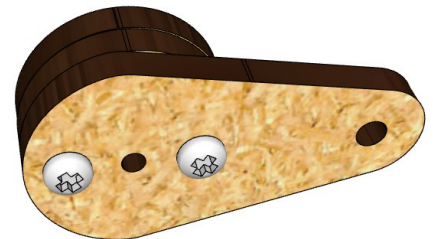

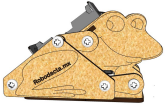

16

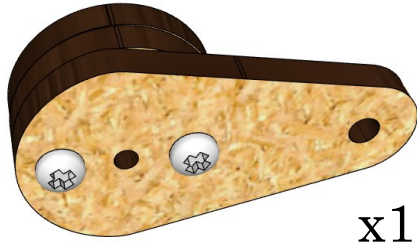

x1

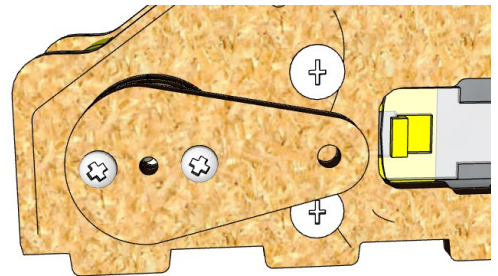
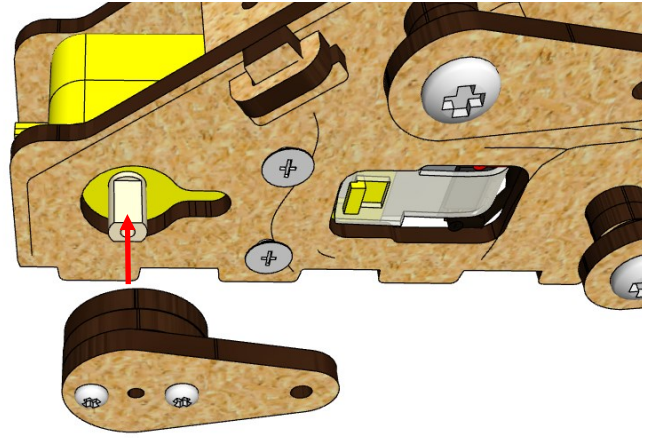

17

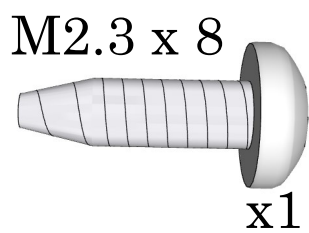

x1

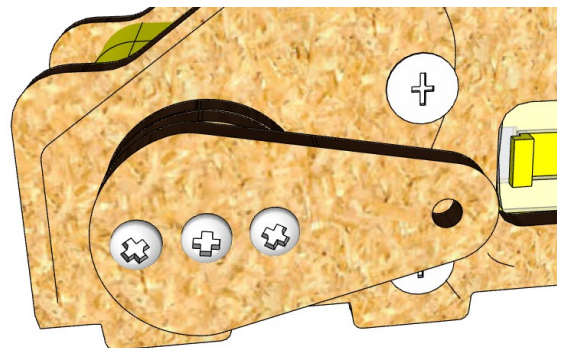
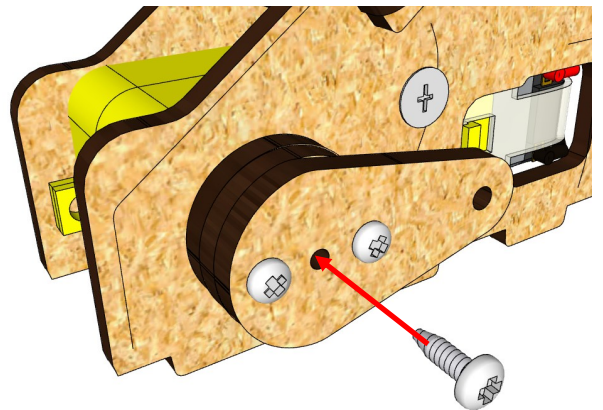

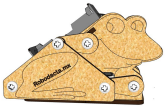

18

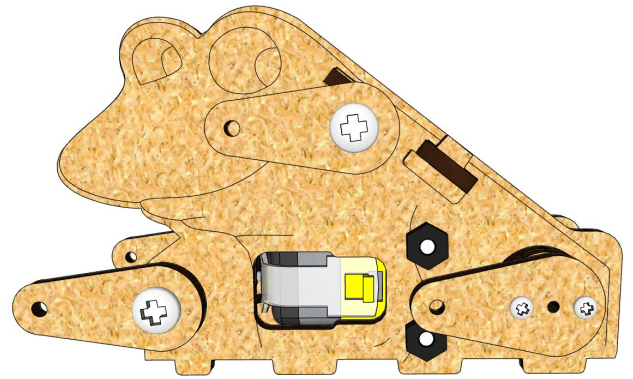
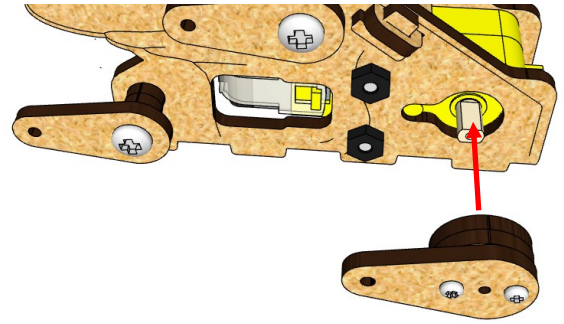
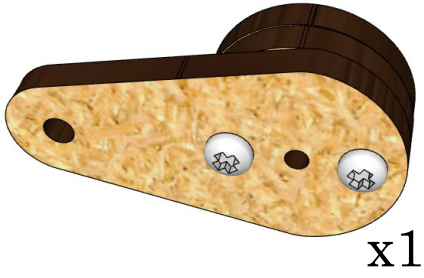

19

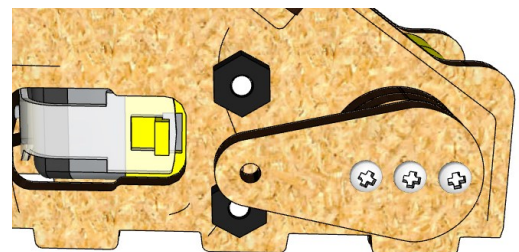
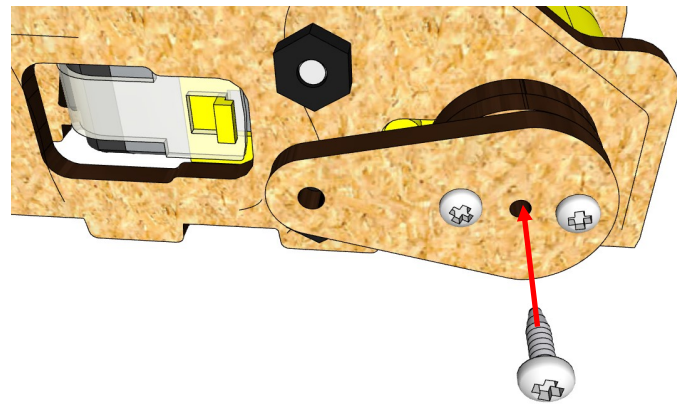
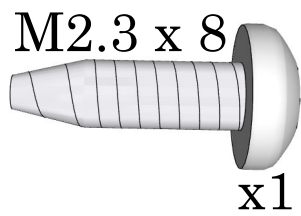

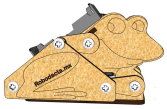

20

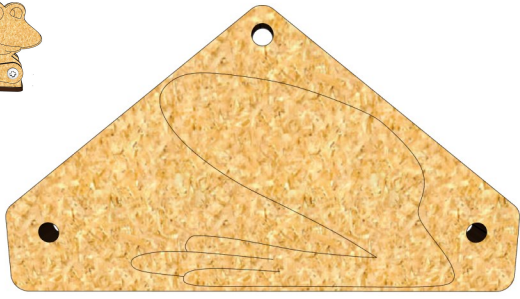

x1

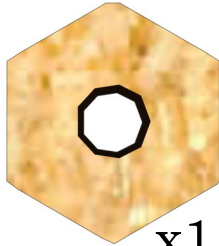

x1

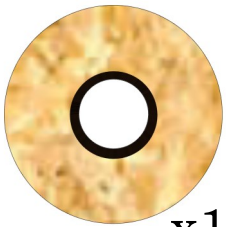

x1

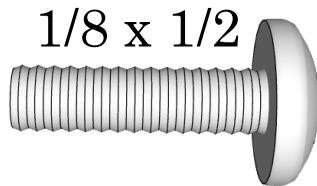

x1

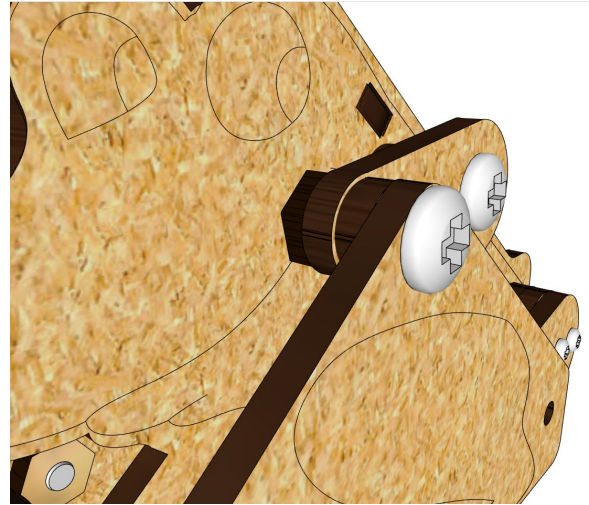
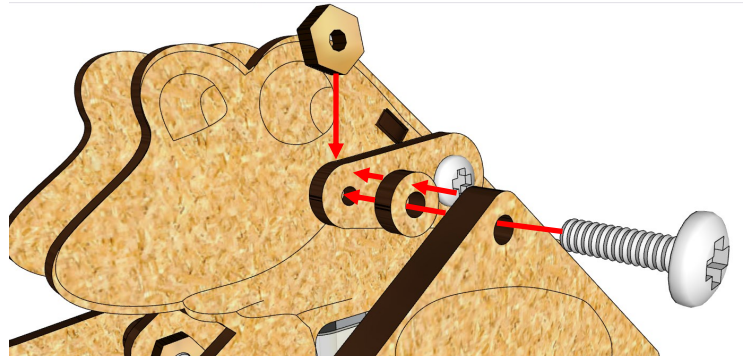

21

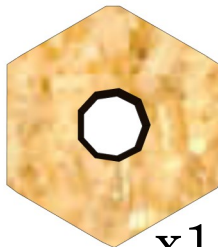

x1

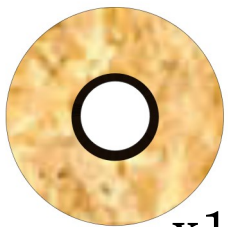

x1

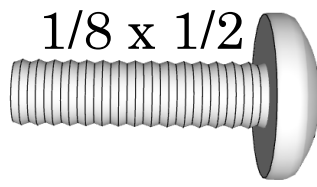

x1

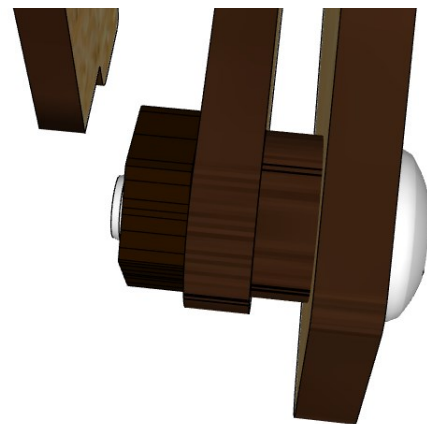
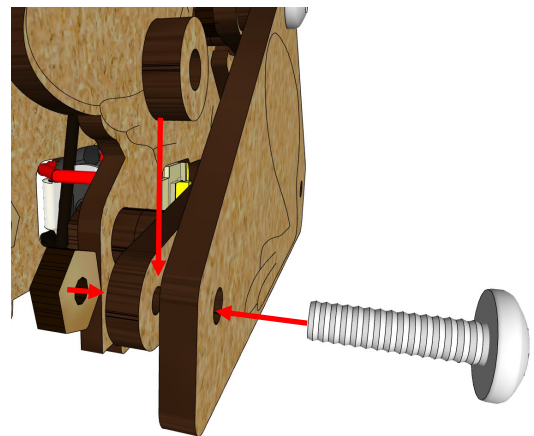

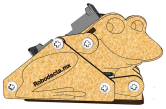

22

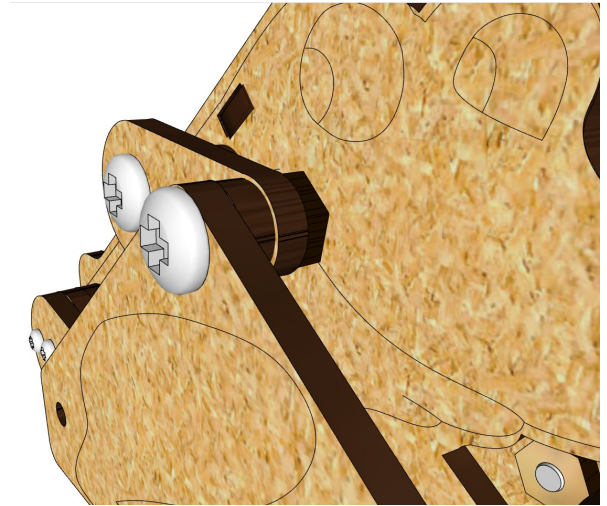
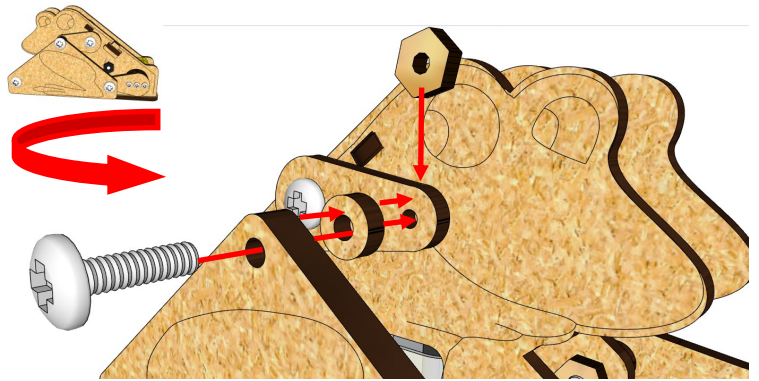
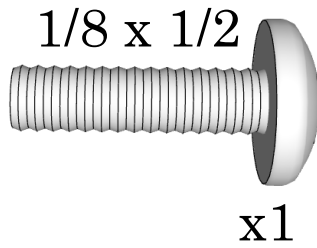
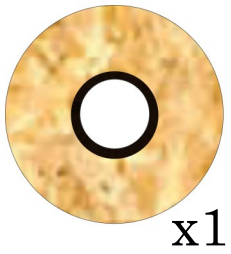
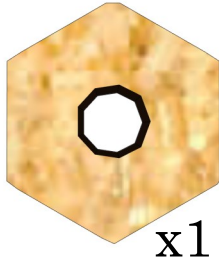

23

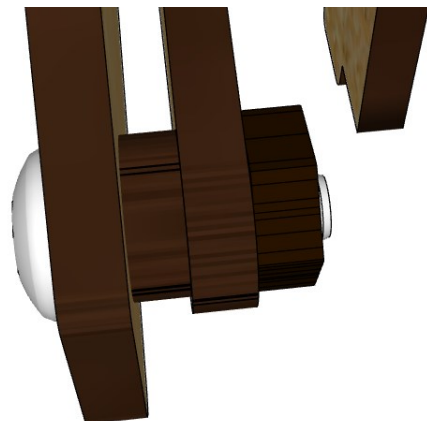
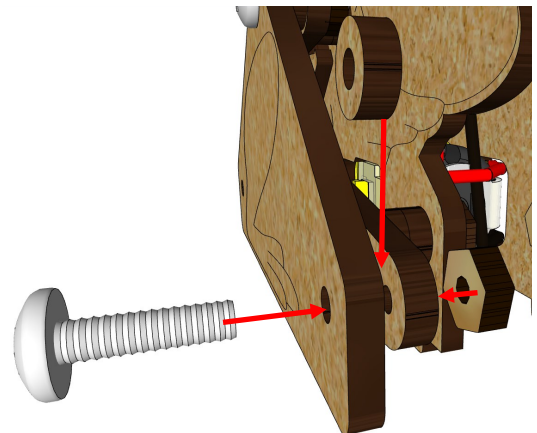
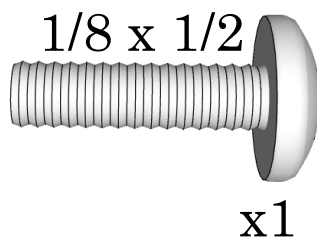
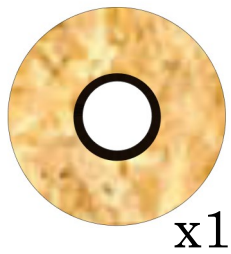
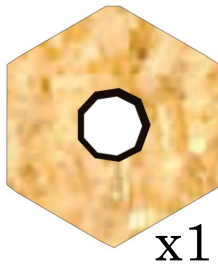

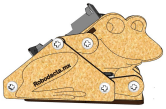

24

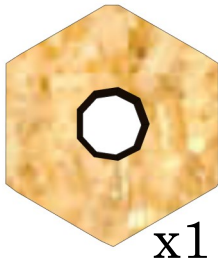

x1

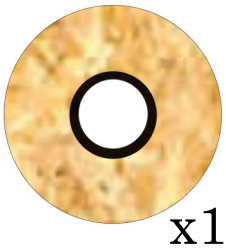

x1

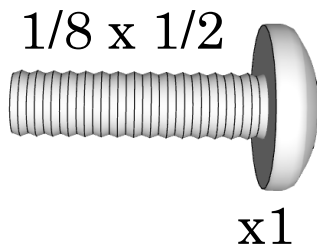

1/8 x 1/2

x1

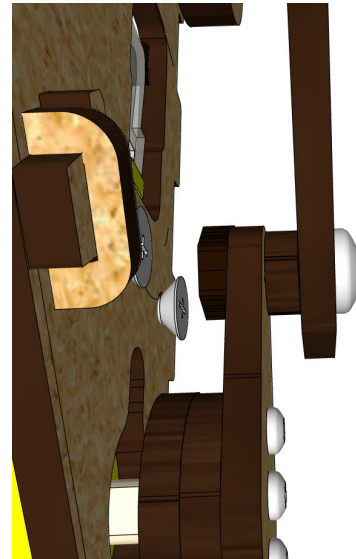
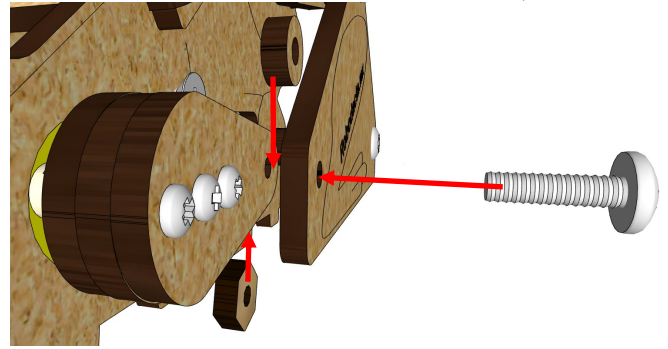

25

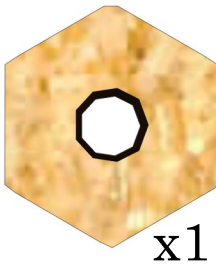

x1

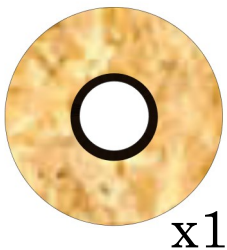

x1

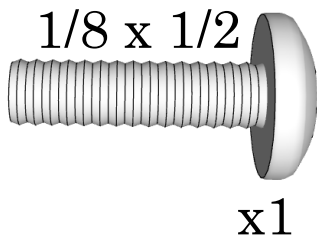

1/8 x 1/2

x1

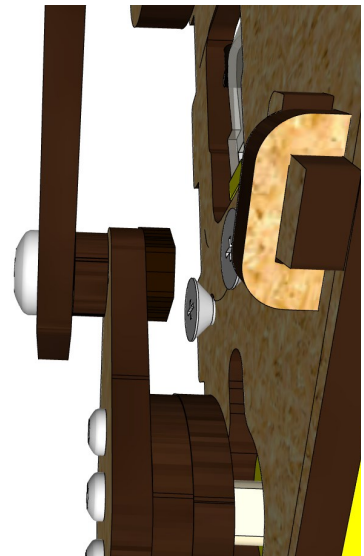
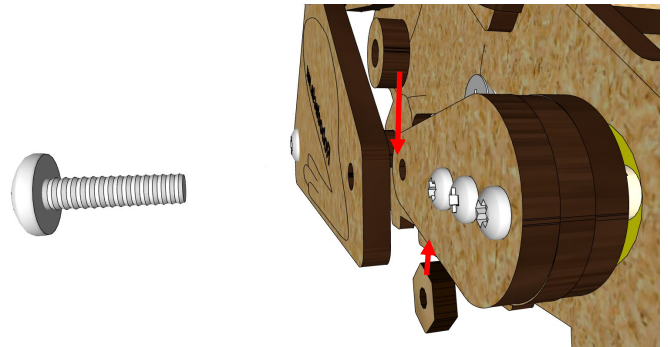

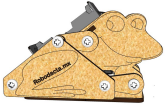

26

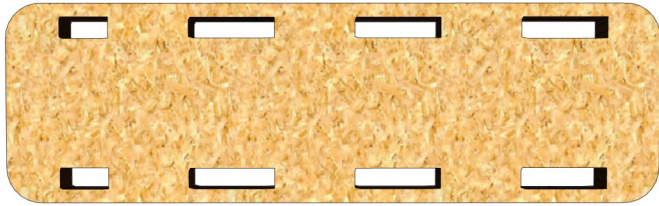

x1

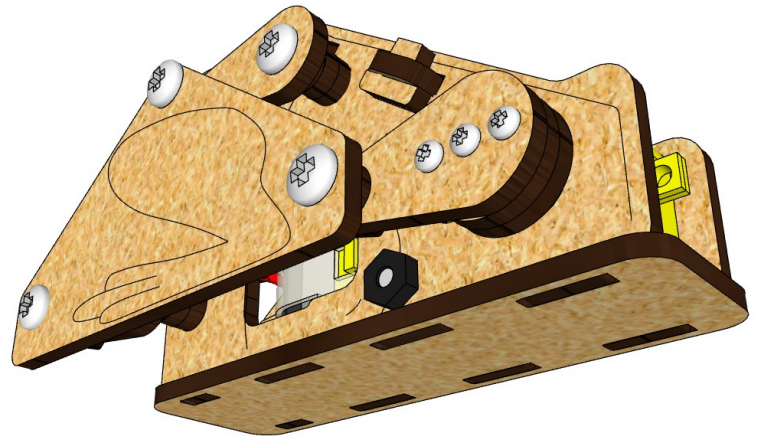
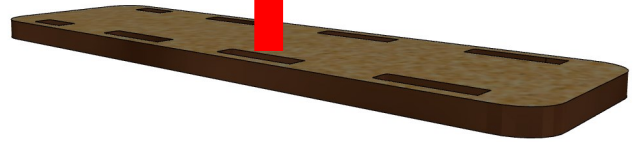
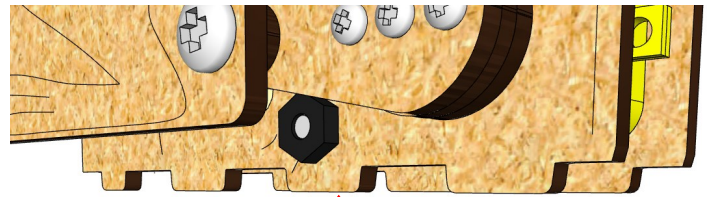

27

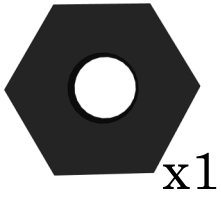

x1



x1

M3 x 12

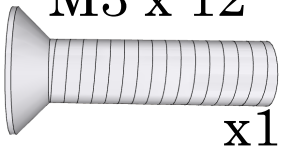

x1

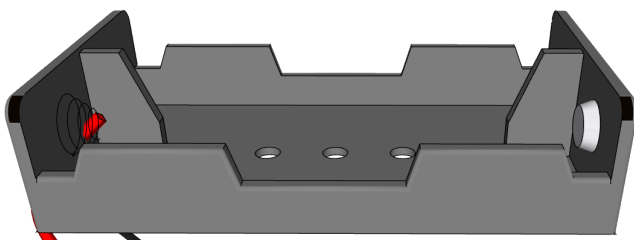
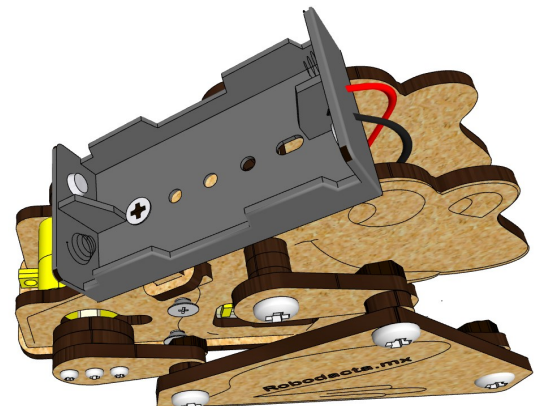
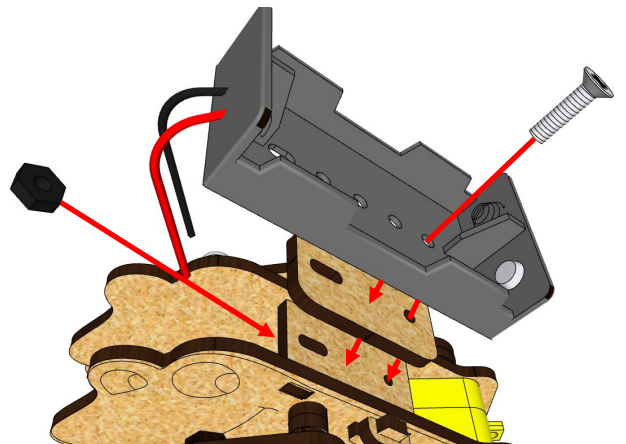

x1

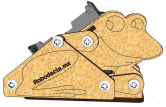

28

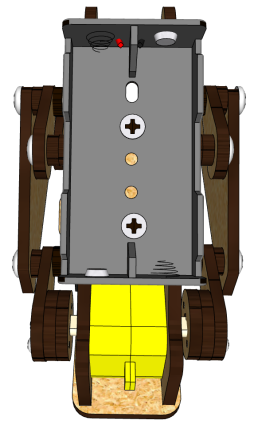
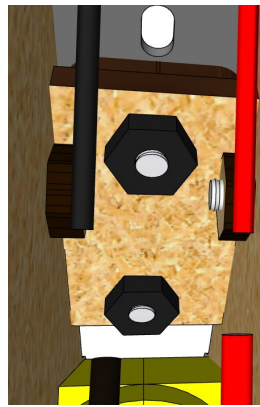
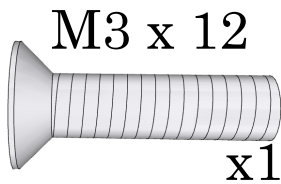
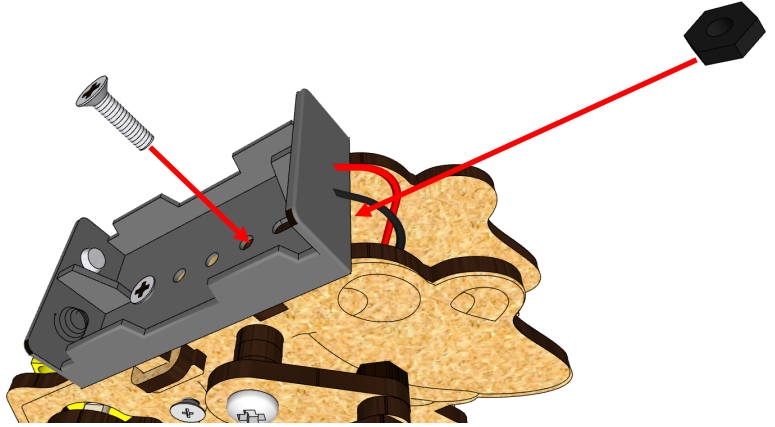
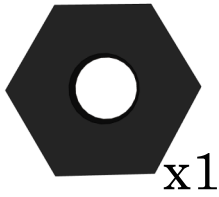

29

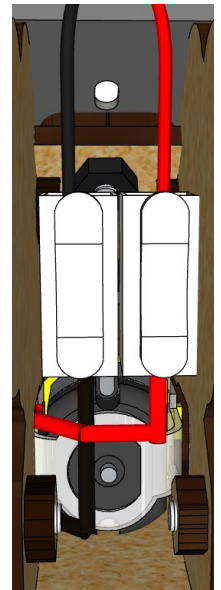
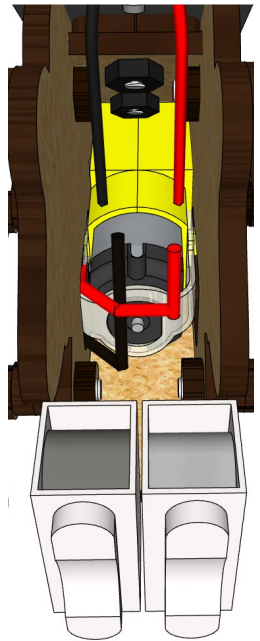
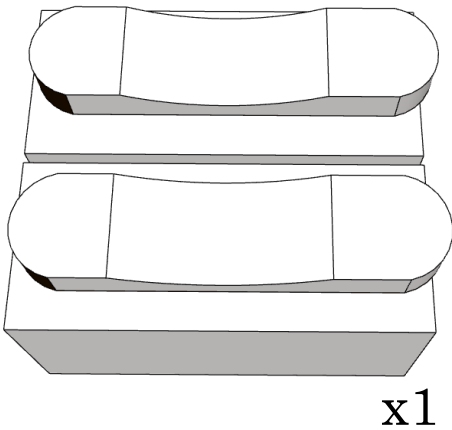

Nota: Presiona uno de los extremos del conector rápido e ingresa uno de los cables, así colocando todos los cables en su debida posición; Corroborra que este sujetando la parte metálica del cable para que haga contacto correctamente.

Tornillería

Utiliza el siguiente esquema para comparar y conocer las medidas de los tornillos y tuercas que necesitas durante el ensamble. Solo basta con colocar encima el tornillo o tuerca hasta que coincida con alguna de las figuras. (Para corroborar correctamente las medidas de los tornillos imprime esta hoja)

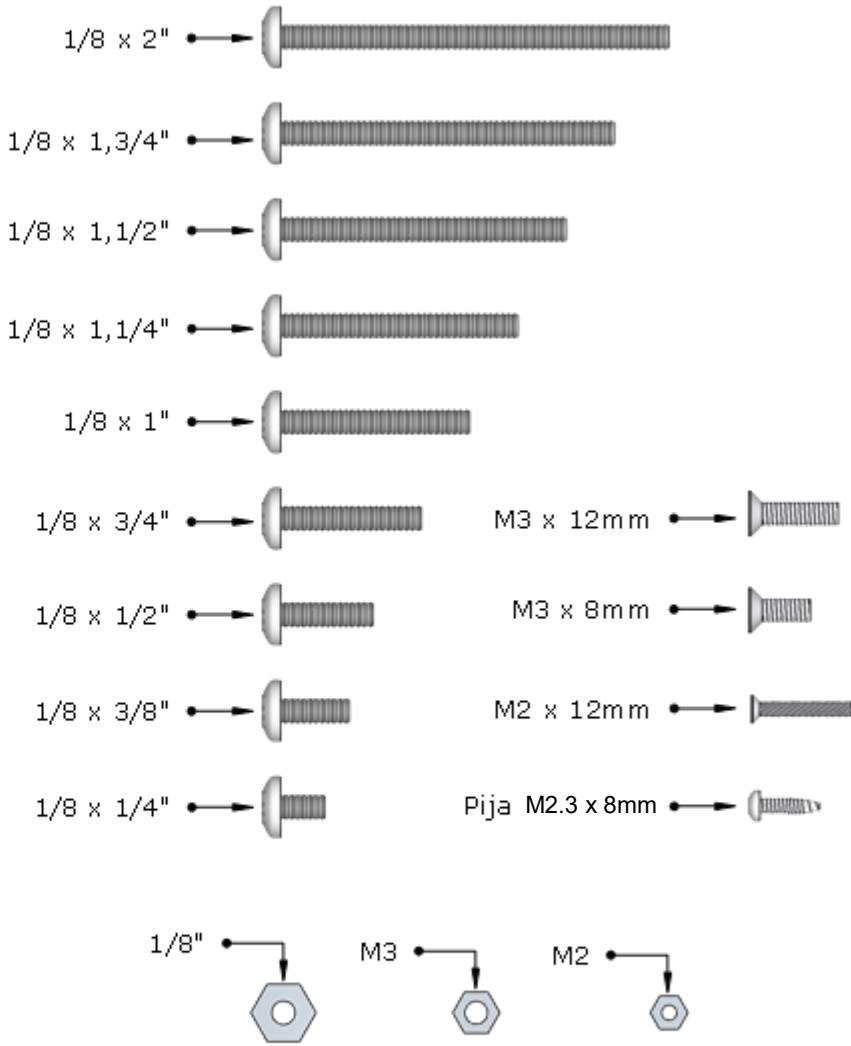

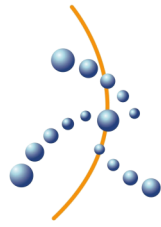

robodacta.mx
robótica didáctica

No te olvides visitar nuestro sitio web y seguirnos en nuestras redes sociales donde encontrarás más contenido.

www.robodacta.mx



@Robodacta.RD



56 28 08 95 23



@robodacta.mx



RobodactaMx